

NSKHPS - BSBD SERIES BALL SCREW SUPPORT BEARINGS

NSK's BSBD series of support bearings for ball screw drives are designed to meet the demanding requirements of modern machine tools, where ball screws must accurately position a work piece or machine component quickly and efficiently. A double row configuration, with a 60° contact angle, enables the bearings to support large axial forces in both directions with accuracy and rigidity. The bearings are supplied sealed, greased for life and ready for easy installation for both housing mounting (BSN type) and direct mounting (BSF type).

DESIGN FEATURES

- › Available as BSF type for direct/face mounting and BSN type for housing mounting
- › Low friction, multi-lip contact seal on both sides
- › Greased for life with lithium soap grease
- › Lubricating holes provided
- › Factory set heavy preload
- › Available as a single double-row bearing or as a matched DT pair

CONDITIONS:

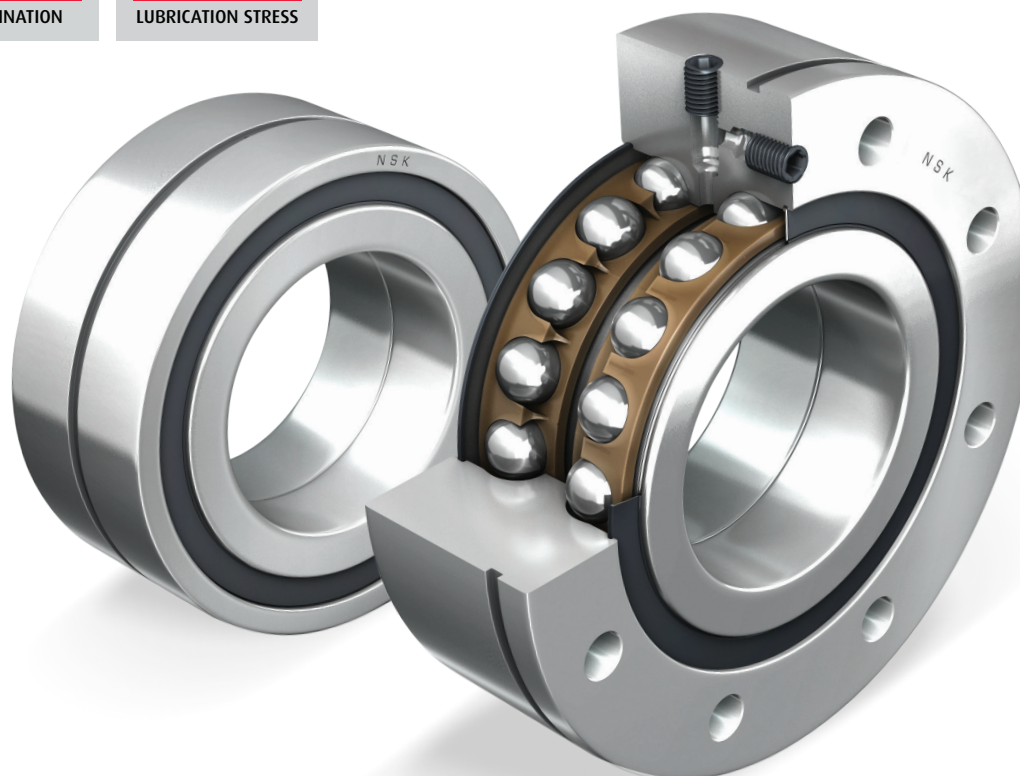
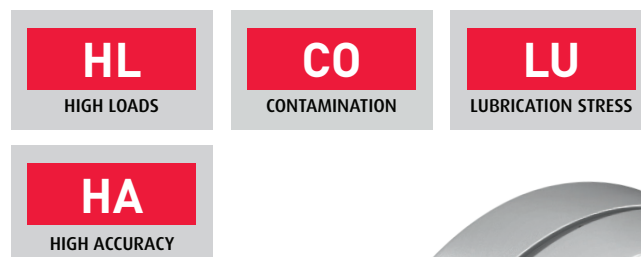

NSKHPS - BSBD SERIES BALL SCREW SUPPORT BEARINGS

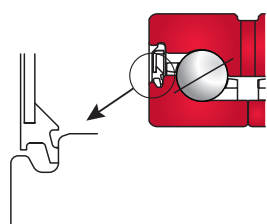
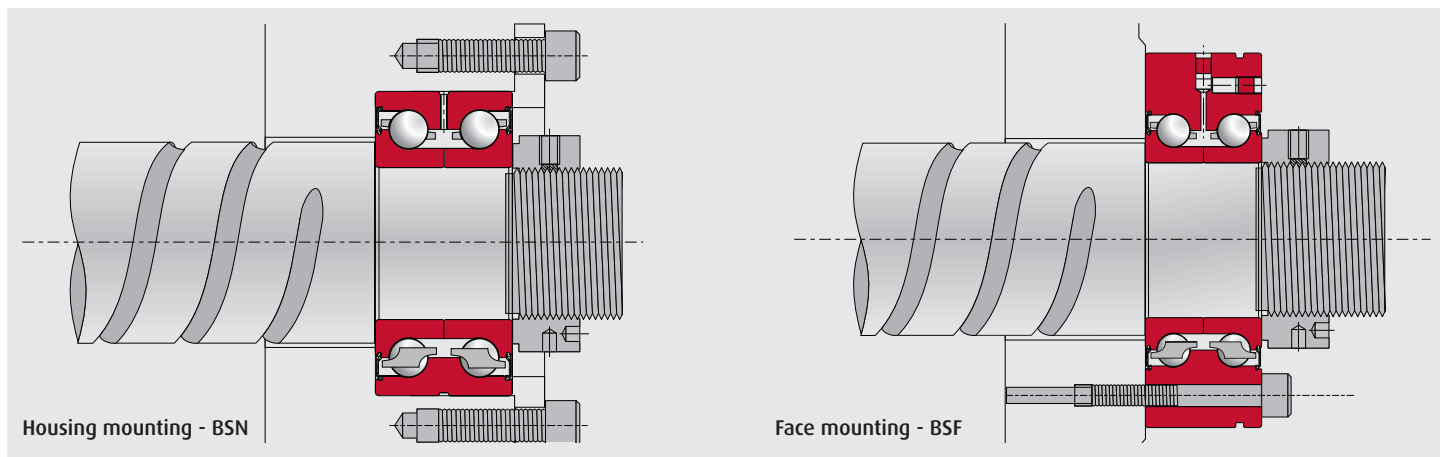

Low friction contact lip seals with triple lip structure achieve high grease retention and dust-proof performance while allowing high speeds.

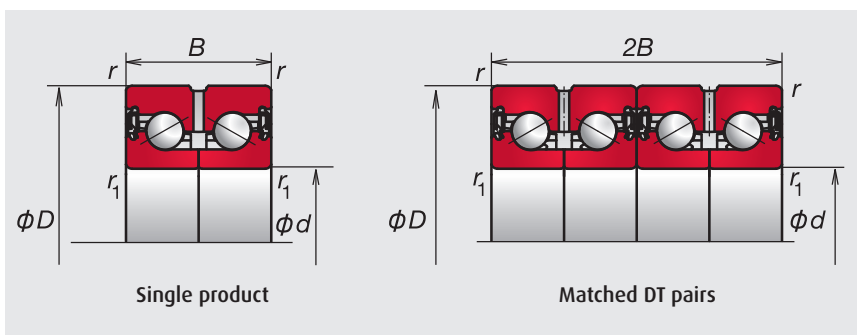

NSK DESIGN SPECIFICATIONS

BS	F	30	80	DDU	H	P2B	DT
BEARING SERIES	BEARING TYPE	BORE DIAMETER	OUTER DIAMETER	SEALS	PRELOAD	ACCURACY	ARRANGEMENT
BS: Double row angular contact thrust ball bearing	F: Flange type N: No flange	Single: 12mm - 60mm DT: 17mm - 50mm	Single: 55mm - 145mm DT: 62mm - 140mm	DDU: Contact-type triple lip	H: Heavy preload standard	P2B: ISO Class 2 running accuracy, all else NSK-specific accuracy	Blank: Single bearing DT: Matched pair

INA INTERCHANGE

ZKL	F	30	80	-2RS -2Z		BLANK -PE	-2AP
BEARING SERIES	BEARING TYPE	BORE DIAMETER	OUTER DIAMETER	SEALS	PRELOAD	ACCURACY	ARRANGEMENT